

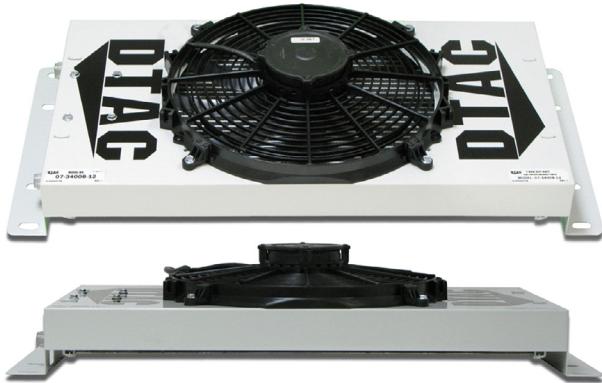

REMOTE CONDENSERS

34008 & 34010 Series

Remote Mount Condenser



FEATURES

- Available 12 or 24 Volt
- 14" Low Profile Fan (07-34008)
- 11" Low Profile Fan (07-34010)
- Water Resistant Motors
- Steel Case with Black Powder Coat Finish

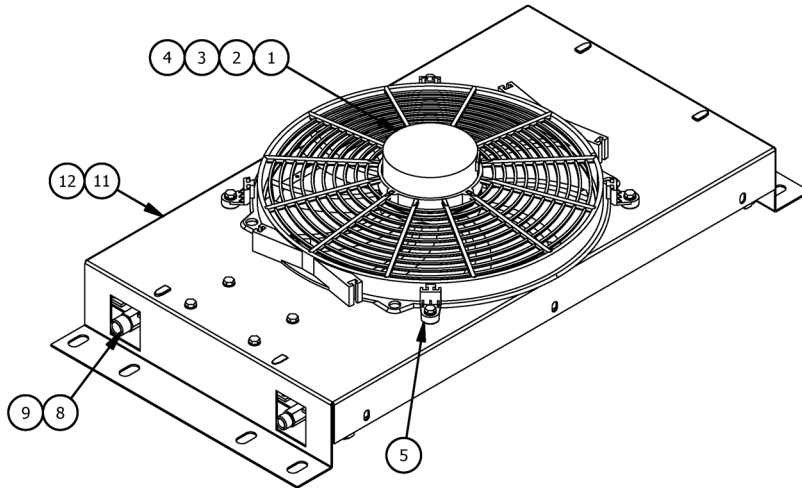

07-34008 & 07-34010 PARTS LIST

ITEM	QTY 07-34008-12	QTY 07-34008-24	QTY 07-34010-12	QTY 07-34010-24	DTAC NO.	DESCRIPTION	NOTE
1	0	0	1	0	02-4011S	11" Fan Asm, 12V Puller	
2	0	0	0	1	02-4011S-24	11" Fan Asm, 24V Puller	
3	1	0	0	0	02-4014S	14" Fan Asm, 12V Puller	
4	0	1	0	0	02-4014S-24	14" Fan Asm, 24V Puller	
5	4	4	4	4	02-50025	Mount Leg	
6	1	0	1	0	03-01702	12V Relay	1
7	0	1	0	1	03-01704	24V Relay	1
8	1	1	0	0	07-01438	Condenser Coil	
9	0	0	1	1	07-01490	Condenser Coil	
10	1	1	1	1	12-00098	Wire Harness	1
11	1	1	0	0	34-00008	Housing, 34008	
12	0	0	1	1	34-00010	Housing, 34010	
13					Note 1	Not Shown	

BTU'S COOL	AIR FLOW	HEIGHT	WIDTH	DEPTH	WEIGHT	MOTOR	CURRENT DRAW	DTAC NO.
35,000	790 CFM	5.75"	30.5"	14.75"	27 LBS	1-12V	10.7 AMPS @ 13.6 VDC	07-34008-12
"	"	"	"	"	"	1-24V	5.6 AMPS @ 26.8 VDC	07-34008-24
25,000	690 CFM	"	"	"	"	1-12V	10.7 AMPS @ 13.6 VDC	07-34010-12
"	"	"	"	"	"	1-24V	5.6 AMPS @ 26.8 VDC	07-34010-24

REMOTE CONDENSERS



PREVENTATIVE MAINTENANCE

DTAC strives to manufacture A/C systems of superior quality. However, as with all mechanical equipment, normal maintenance must be performed for your A/C to function at peak capacity. A well-maintained A/C system will save on down time and premature component failures.

Weekly inspections or every 2 days in severe environments should include:

1. Inspect compressor clutch drive belts (tightness, wear).
2. Inspect compressor mounting brackets (bolts, alignment).
3. Inspect mounting hardware on evaporator unit and condensers.
4. Inspect air intake filter. (Clean or replace filter).
5. Inspect evaporator and condenser coils. (Clean using air pressure. **DO NOT USE WATER OR PRESSURE WASHERS**).
6. Inspect hose and wire harness for proper routing, leaks and wear.

Helpful Hints

Make sure the evaporator air intake area is not obstructed (i.e. toolboxes, clothing, lunch box, etc.).

Manual thermostats on our systems, when rotated clockwise to the stop position will not allow the A/C compressor clutch to cycle. The compressor will run continuously and the evaporator coil will not defrost. **REMEDY:** Turn the manual thermostat knob clockwise to the stop position, then turn the thermostat knob back counter clockwise $\frac{1}{4}$ turn.

DTAC thanks you for purchasing our units. It is our endeavor to provide you with a quality A/C unit with trouble free service.