



# EVAPORATORS

## 315-HC Series

Heat/Cool, Ceiling Mount



### FEATURES

- Available 12 or 24 Volt
- Heavy Duty Metal Construction (Eliminates Broken Plastic Cases & Drain Tubes)
- Removable Lid for Easy Access
- Filtered Air Intake
- Blower Assembly Enclosed Inside Case for Increased Safety
- 6 -3.5" Directional Round Louvers for Maximum Air Flow
- Steel Case with Black Powder Coat Finish

### OPTIONS

- Outside Air Adapter for Pressurization P/N 11-52104

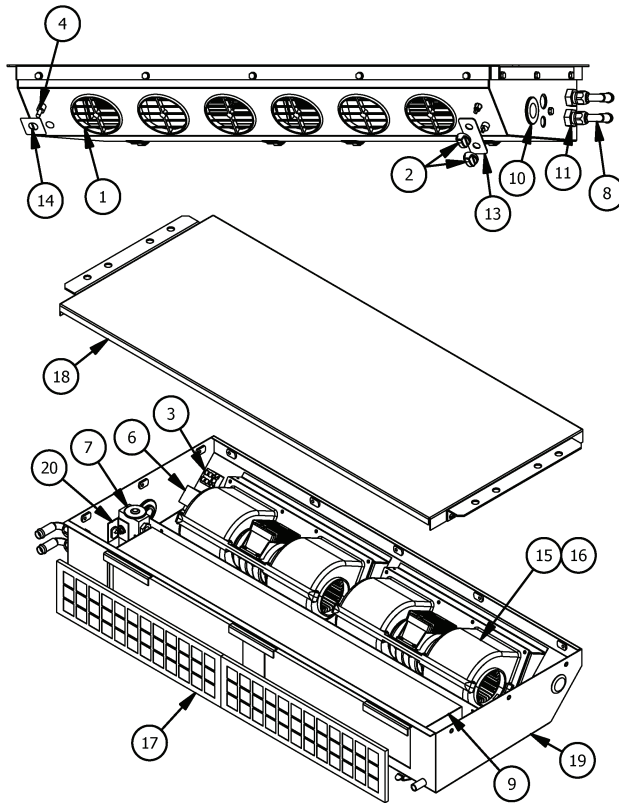

315-HC PARTS LIST					
ITEM	QTY 12V	QTY 24V	DTAC NO.	DESCRIPTION	NOTE
1	6	6	02-16061	3-1/2" Louver	
2	2	2	03-00165	Knob	
3	1	1	03-13006	Rotary 3-Speed Switch	
4	1	1	03-13020	Toggle Switch	
5	1	1	03-13029	40 Amp Circuit Breaker	1
6	1	1	03-14002	Rotary Thermostat	
7	1	1	04-15004	Block Expansion Valve	
8	2	2	05-00301	90 Deg. Heater Fitting	
9	1	1	07-00315	Heat\Cool Evap Coil	
10	1	1	09-00621	One Inch Grommet	
11	2	2	09-50004	#8 MIO Bulkhead w Jam Nut	
12	1	1	12-00315	Wire Harness	1
13	1	1	12-50419	Faceplate	
14	1	1	12-50420	Face Plate - Heat/Cool	
15	2	0	30-51580	12V Blower Assembly	
16	0	2	30-51581	24V Blower Assembly	
17	2	2	31-50000	FILTER 315	
18	1	1	31-50001	Lid	
19	1	1	31-50002	Housing	
20	1	1	50-50500	Expansion Valve Mnt Brkt	
21	*		Note 1	Not Shown	

BTU'S HEAT	BTU'S COOL	AIR FLOW	HEIGHT	WIDTH	DEPTH	WEIGHT	MOTOR	CURRENT DRAW	DTAC NO.
22,000	33,000	410 CFM	5"	35.5"	14.75"	48 LBS	2-12V	24 AMPS @ 13.6 VDC	315-12HC
"	"	"	"	"	"	"	2-24V	14 AMPS @ 27 VDC	315-24HC

EVAPORATORS



# 315 SERIES

## Installation Instructions

---

Ceiling mounted units are designed to be installed inside the cab of the vehicle with nothing protruding above the cab except the bolts used to secure the unit to the ceiling. The ceiling mounted units are especially adapted to heavy equipment because they are installed in the upper body area of the operator. They provide serviceability, and are typically located in the cleanest region of the vehicle cab. These attributes and the fact that wall space is not available in many cabs, make ceiling mount units a popular choice. **NOTE: 300 SERIES UNITS ARE DESIGNED FOR HORIZONTAL MOUNTING.**

### MOUNTING LOCATION

Choose a location that:

1. Provides the operator maximum head clearance.
2. Provides operator maximum accessibility to controls and airflow.
3. Provides operator freedom of movement and does not restrict exists.
4. Provides serviceability: fan and motor, switches and expansion valve.
5. Provides best routing of refrigerant and heater lines (if so equipped), drain hoses and wiring harnesses.
6. Provides adequate space for hooking up pressurizers and/or filters if needed.
7. Gives sufficient clearance for air intake at rear of unit (usually 2" from rear of unit).
8. Make sure unit is tilted slightly down at drain openings.

### CLEARANCES

Take into consideration fuel and hydraulic tanks, electrical panels, window openings, emergency exits, and safety devices (i.e. water tanks, fire extinguisher systems, electrical or fuel shutdown switches etc.). Make sure that all mounting bolts, brackets, hoses and harnesses do not obstruct the operator's vision!

### INSTALLATION

1. Select mounting area.
2. Remove bolts from the front of unit, and use the top plate as a template to mark mounting hole locations (units 300 and 301 only).
3. Mark and drill mounting bolt holes (5/16" for 300 and 301).
4. Bolt top plate to ceiling and seal bolts with Silicone.
5. Lift lower case; hook rear studs into hinge arms on top plate. Unit will now swing up into top plate. Reinstall bolts to secure top and bottom plate (units 300 and 301 only).
6. (For 302 and 310 units), set unit in select mounting area. Mark and drill mounting holes.
7. Follow instructions for mounting the other supporting components (i.e. condenser, compressor, drier, safety switches, etc.).
8. Installation of the refrigerant hoses (refer to plumbing schematic on page 3).
9. Install heater hoses with water cut-offs as needed (301 only).

### DRAIN HOSE INSTALLATION TIPS

1. To avoid restrictions, install drain hose using care not to kink or pinch.
2. Drain hoses on dual drain units may be tied together if the installation warrants.
3. Install rubber kazoo tube to the lower end of drain hose/hoses to avoid air bubbles being trapped which may prevent drainage.
4. Drain hoses should always be routed outside of cab.
5. Seal around drain hoses where they exit cab to minimize dirt and hot air entering cab.
6. Clean out hoses periodically.

## DRIER INSTALLATION TIPS

NOTE: DTAC presently utilizes only pickup tube, stack pack, sight-glassed receiver-driers compatible with both R-12 and R-134A refrigerants. These driers are specifically designed to be mounted in a vertical attitude. This vertical attitude is with the sight-glass up. Any deviation from this present policy would be clearly noted by DTAC. Failure to mount the drier as outlined below, could result in your warranty being voided.

Guidelines are:

1. Drier should be mounted in a vertical position (sight glass up).
2. No. 6 line from condenser should be attached to the drier fitting port marked "IN".
3. Drier should be securely mounted in a manner to minimize any excessive vibration.
4. Clearance should be allowed for any safety switches and the wiring for these switches.

## CONDENSER INSTALLATION TIPS

### RADIATOR MOUNTED CONDENSER

1. Install with the #8 (large) fitting up when possible (to help minimize backpressure).
2. Install condenser in maximum cool airflow area.
3. Always try to allow condenser to get the cool air first. Mounting condenser behind a hydraulic oil, engine oil or engine coolant coil could affect the condensers efficiency.

### REMOTE MOUNTED CONDENSER

1. Install condenser with at least 3" free air space in all directions.
2. **DO NOT INSTALL IN THE PATH OF ENGINE EXHAUST.**
3. Install in clean air area if possible.
4. Exhausted air off of condenser should not blow onto cab skin or cab glass.
5. Protective covers over condensers should not restrict airflow.

## COMPRESSOR INSTALLATION

See Compressor Mounting Instructions supplied in mount kit.

## PLUMBING INSTALLATION

Plumbing schematic below is provided to speed installation of hoses.

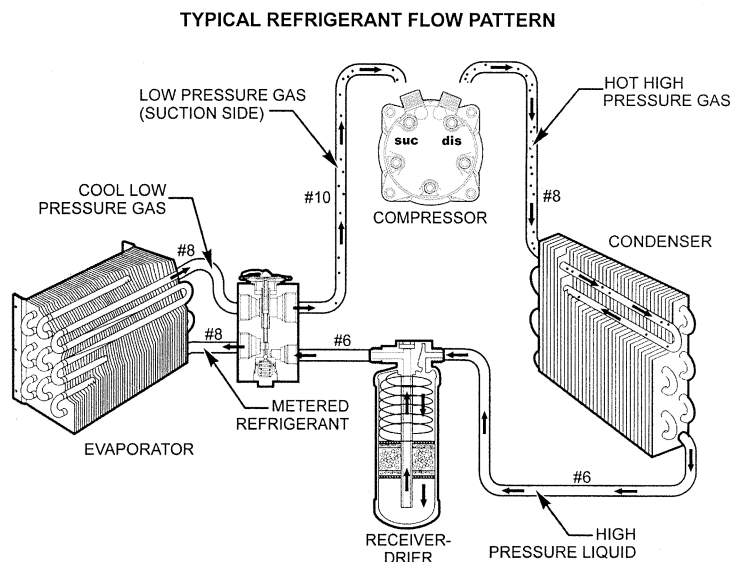

# WIRING INSTALLATION

## INTERNAL WIRING SCHEMATIC

Refer to Internal Wiring Schematic supplied on unit parts breakdown that is enclosed with the unit.

### BINARY SAFETY SWITCH WIRING SCHEMATIC

NOTE: The A/C unit and remote condenser are internally grounded. EXCEPTION: The remote condenser, P.N. 07-34002-12/24 has external ground.

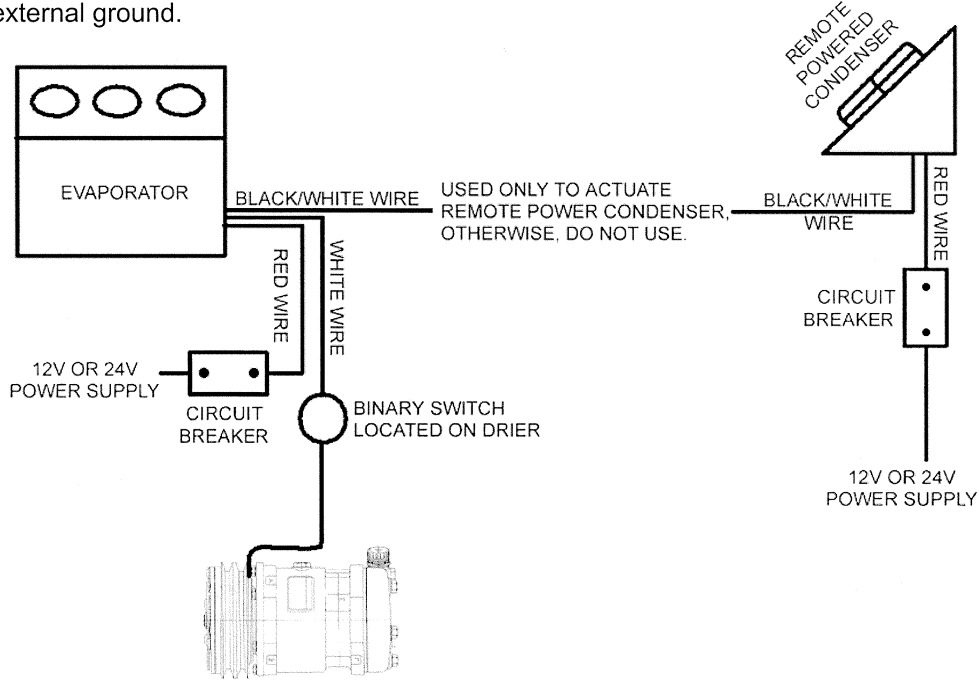

### HI & LOW PRESSURE SAFETY SWITCHES WIRING SCHEMATIC

NOTE: The A/C unit and remote condenser are internally grounded. EXCEPTION: The remote condenser, P.N. 07-34002-12/24 has external ground.

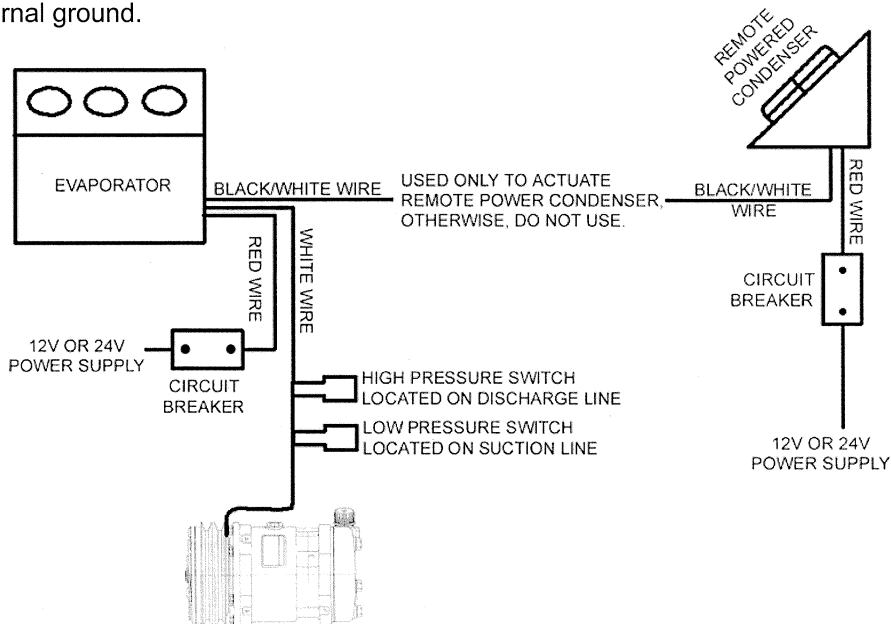

Manufacturer of Heavy Equipment Heat/Cool Systems  
"Revolutionizing the Heavy Equipment A/C Industry"

1.800.527.9477  
www.dtac.com



## PREVENTATIVE MAINTENANCE

DTAC strives to manufacture A/C systems of superior quality. However, as with all mechanical equipment, normal maintenance must be performed for your A/C to function at peak capacity. A well-maintained A/C system will save on down time and premature component failures.

**Weekly inspections or every 2 days in severe environments should include:**

1. Inspect compressor clutch drive belts (tightness, wear).
2. Inspect compressor mounting brackets (bolts, alignment).
3. Inspect mounting hardware on evaporator unit and condensers.
4. Inspect air intake filter. (Clean or replace filter).
5. Inspect evaporator and condenser coils. (Clean using air pressure. **DO NOT USE WATER OR PRESSURE WASHERS**).
6. Inspect hose and wire harness for proper routing, leaks and wear.

### Helpful Hints

Make sure the evaporator air intake area is not obstructed (i.e. toolboxes, clothing, lunch box, etc.).

Manual thermostats on our systems, when rotated clockwise to the stop position will not allow the A/C compressor clutch to cycle. The compressor will run continuously and the evaporator coil will not defrost. **REMEDY:** Turn the manual thermostat knob clockwise to the stop position, then turn the thermostat knob back counter clockwise  $\frac{1}{4}$  turn.

DTAC thanks you for purchasing our units. It is our endeavor to provide you with a quality A/C unit with trouble free service.

# Tech Knowledge



## Charging A/C System Procedures

- I. Leak Testing Procedure
- II. Evacuating System Procedure
- III. Charging Procedure
- IV. Determine Refrigerant Weight Procedure

### I. Leak Testing Procedure

1. With machine engine off, connect gauges to A/C system.
2. Charge with dry nitrogen. Up to 300 psi may be necessary to detect some leaks.
3. Spray all fittings and areas of concern with soapy water.
4. If bubbles are present or nitrogen pressures drop in fifteen minutes, repair leak and perform leak test again.
5. If nitrogen pressures maintain a constant level for fifteen minutes and no bubbles are present, proceed to the evacuating procedure.

### II. Evacuating System Procedure

1. With machine engine off, connect gauges to A/C system.
2. Install center hose from gauge manifold to vacuum pump.
3. Turn the vacuum pump on.
4. Open the high and low side gauge manifold valves and the pump exhaust valves. System should reach 28-29.5 inches Hg. in less than 5 minutes. If system does not pump down, check connections and return to leak testing procedures if necessary.
5. Evacuate system using vacuum pump for an average of one hour depending on size of pump. This is crucial to remove moisture and air from the system.
6. Close all valves.
7. Shut off vacuum pump.
8. If pressures rise in 5 minutes, check connections and return to leak testing procedures if necessary.
9. If pressures hold level in a vacuum for 5 minutes proceed to charging procedures.

### III. Charging Procedure

1. The system must be in a vacuum to continue.
2. Place refrigerant bottle on scales.
3. Attach charging hose to refrigerant bottle.
4. Purge air from charging hose.
5. Open shut-off valve at refrigerant bottle.
6. Reset scales to zero if necessary.
7. With machine off, open high side manifold valve.
8. After gauge pressures become slow to increase, close high side manifold valve.
9. Start engine and throttle to working rpm.
10. Adjust A/C controls for maximum cooling and engage compressor clutch.
11. Open low side manifold valve.
12. Charge to weight recommended by manufacturer.
13. Check system for cooling.
14. If recommended weight is not available proceed to determine refrigerant weight procedure.

### IV. Determine Refrigerant Weight Procedure

1. Watch sight glass on drier. If bubbles clear on sight glass, system is full. However, some systems are full and still have bubbles in sight glass. Do not try to clear all bubbles if high side pressure is too high.
2. Try to keep low side pressure between 5-35 psi and the high side pressure lower than 295 psi. Keep in mind that pressure readings are greatly affected by ambient temperatures. For example, a high side reading of 295 psi on a 75 degree day would not be good while a high side reading of 300 psi on a 115 degree day would be acceptable, assuming the A/C system was cooling good.
3. Monitor vent temperature with doors closed to cab. If adding refrigerant lowers vent temperature, keep adding refrigerant as long as high side pressure is acceptable. When vent temperature levels out or starts rising, stop adding refrigerant. A 20-degree difference between the vent temperature and the air intake temperature is acceptable.
4. Return line at compressor should be cool and possibly sweating.
5. Cab temperature should be comfortable.
6. Check scales for proper weight and record for future use.

Contact one of our A/C specialists for further questions.  
1.800.527.9477



Manufacturer of Heavy Equipment Heat/Cool Systems  
"Revolutionizing the Heavy Equipment A/C Industry"

---