



EVAPORATORS

702 Series

Heat/Cool, Rooftop Mount



FEATURES

- Electronic Water Valve
- Three Speed Blower Motor
- Preset Thermostat
- Rubber Latched Cover for Easy Service Access

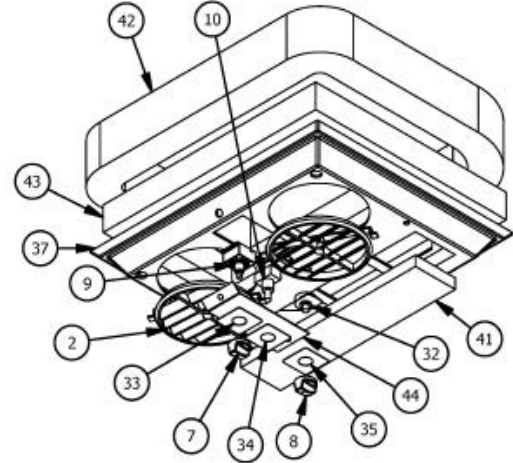
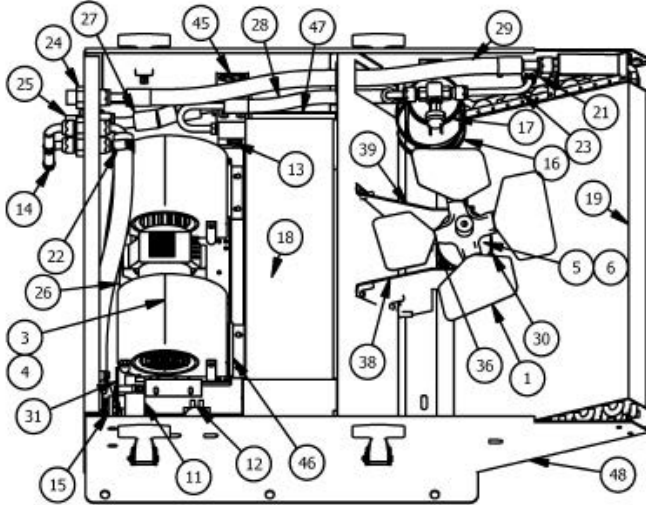

PARTS LIST						PARTS LIST					
ITEM	QTY 12V	QTY 24V	DTAC NO.	DESCRIPTION	NOTE	ITEM	QTY 12V	QTY 24V	DTAC NO.	DESCRIPTION	NOTE
1	1	1	02-16008	Fan Blade		26	3	3	10-00058	5/8" Heater Hose	
2	2	2	02-16065	Louver		27	1	1	10-70210	#10 Hose Assy	
3	1	0	02-17408	12V Blower Assy.		28	1	1	10-70206	#6 Hose Assy	
4	0	1	02-17509	24V Blower Assembly		29	1	1	10-70208	#8 Hose Assy	
5	1	0	02-48005	12V Cond. Motor		30	1	1	12-00130	Top Motor Mount	
6	0	1	02-48105	24V Cond. Motor		31	1	1	12-00240	WV Brkt	
7	1	1	03-00165	Knob		32	1	1	12-43411	Actuator Wire Harness	
8	1	1	03-00166	Knob		33	1	1	12-50419	Face Plate	
9	1	1	03-13006	3 SPEED SWITCH		34	1	1	12-50421	Face Plate - Air Increase	
10	1	1	03-13020	H/C Toggle Switch		35	1	1	12-50741	Face Plate - H/C WV	
11	1	1	03-13027	Actuator Control		36	1	1	40-00005	Top Motor Mount	
12	1	1	03-14013	Thermostat		37	1	1	70-00001	Plenum	
13	1	1	04-15004	Block Expansion Valve		38	1	1	70-00006	Motor Mount Left	
14	4	4	05-00301	90 Deg Heater Fitting		39	1	1	70-00007	Motor Mount Right	
15	1	1	05-00908A	Water Valve Assy.		40	1	1	70-00016	Wire Harness	1
16	1	1	06-10107	Drier Brkt		41	1	1	70-50321	Foam Filter	
17	1	1	06-12067	06-12058-1 w/ 03-34070		42	1	1	70-50323	D-Ring Insulation	
18	1	1	07-00702	Evaporator Coil		43	1	1	70-50324	Foam Insulation	
19	1	1	07-00701	Cond Coil		44	1	1	70-51585	Switch Panel	
20	1	1	07-36008	Grille	1	45	1	1	70-51587	Block Vlv Brkt	
21	1	1	09-02676BL	#6 FM to Male Adapter		46	4	4	70-51590	Blower Retainer Bracket	
22	6	6	09-04000	Hose Clamp #6/#8		47	1	1	70-51591	Drain Pan 700	
23	1	1	09-38276	No.6 Spec Fitting		48	1	1	70-51594	Bottom Housing	
24	3	3	09-50004	#8 Bulkhead w Jam Nut		50	1	1	70-51599	Lid	1
25	1	1	09-50005	#10 Bulkhead w Jam Nut		51			Note 1	Item Not Shown	

BTU'S HEAT	BTU'S COOL	AIR FLOW	HEIGHT	WIDTH	DEPTH	WEIGHT	MOTOR	CURRENT DRAW	DTAC NO.
15,500	23,500	345 CFM	13.25"	23.25"	33.5"	100 LBS	1-12V	27 AMPS @ 13.5 VDC	702-12
"	"	"	"	"	"	"	1-24V	14 AMPS @ 26.8 VDC	702-24

EVAPORATORS



700 Series Installation Instructions

NOTE: Choose a mounting location for the unit that will not destroy or void warranty or effectiveness of either the Roll Over Protection Structure or Falling Object Protection Structure.

1. Remove the headliner or loosen enough to drop the center portion. (Disregard if no headliner).
2. Determine the most suitable location for mounting the air conditioning unit. (See Figure 1).
 - A. Mark the front-to-rear centerline of the cab on the outside of the cab roof.
 - B. Place the mounting template on the roof using the centerline as a guide.
 - C. Insure that airflow to the unit is not obstructed.
 - D. Do not mount the unit with the front lower than the rear, as this will prohibit water drainage.
 - E. Avoid cutting roof stiffeners if possible. If stiffeners are cut or roof is weakened due to the cut out, reinforcement may be required.
3. Tape the template to the roof at the desired location. Mark the roof cutout area (scribe the roof).
4. Cut the roof where marked and set unit into plenum hole. Using unit as template, mark and drill (6) 3/8" dia. mounting holes. Remove burrs and sharp edges.

Figure 1: ROOFTOP AIR CONDITIONER INSTALLATION SCHEMATIC

NOTE: Check installation kit to make certain that all parts listed are included.

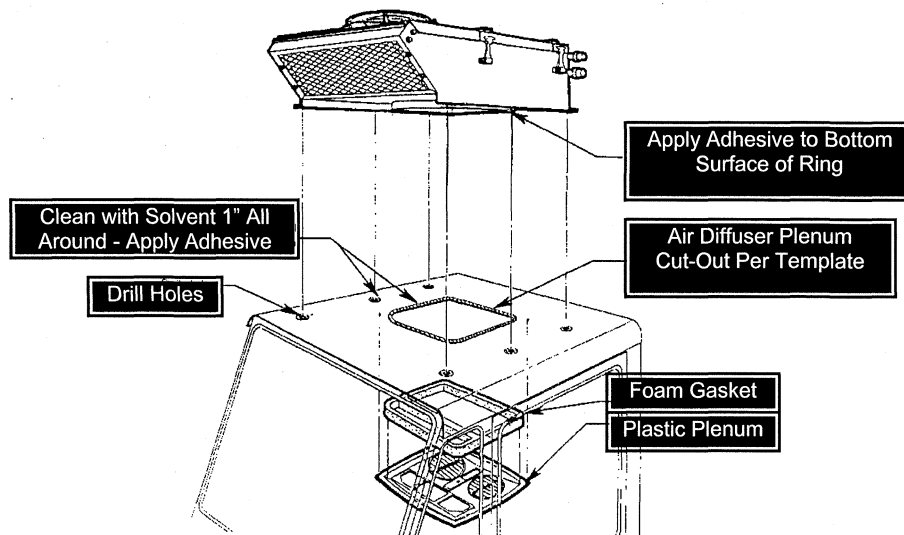

5. Temporarily install the headliner and trace the cutout onto it from the roof. Remove the headliner and cut out the area marked. Use caution and do not cut headliner opening larger than roof opening. (Check against template if in doubt).
6. Should roof reinforcing be required, fabricate and install at this time.
7. Install drain hoses before mounting unit to cab (see drain hose installation).
8. Clean the outside roof area around the cutout and mounting holes using a mild solvent.
9. Apply a thin film of adhesive 1" wide around upper surface of roof cutout and mounting holes. Apply sealer to the face of the sealing ring on the unit. (See Figure 1).
10. Set unit on cab.
11. Apply sealant around bolts and nuts to prevent water leakage into cab.

REFRIGERATION HOSE INSTALLATION

1. Install O-rings and connect hoses to fittings on unit.
2. Clamp hoses within unit using clamps provided.

3. Route hoses over the top of cab and down the back wall to the compressor. On tilt cab vehicles, route hoses to the cab pivot point and then to compressor.
4. Use clamps provided to secure hoses and prevent hose movement. Hoses must not come in contact with hot vehicle components, exhaust manifolds, etc., and they should not be subjected to mechanical abrasions.

DRAIN HOSE INSTALLATION

1. Route the drain tubes to the unit so that they travel in a downward direction from the unit.
2. Cut off the 9/16 OD tubes to length and connect to fittings on unit. Secure drain tubes with tie wraps. Attach to refrigeration hoses only if they run downhill properly.
3. Attach Kazoo tube to end of drain hose(s).

WIRING

1. Disconnect battery.
2. Route red and white wire through 3/4 slot in plenum ring.
3. Red Wire: Connect to an ignition switch supply through a 30 amp circuit breaker (15 amp/24V).
4. White Wire: Connect to compressor clutch. Route the wire around the hinge point before connecting to compressor clutch on tilt-cab installations.

AIR DIFFUSER PLENUM

1. Install headliner. Make sure that wire loom exits plenum ring properly and is not pinched.
2. Place one foam gasket in plastic plenum assembly.
3. Place the plenum assembly up to the unit and start one 10-32x3" screw.
4. Attach the switch-thermostat panel to the plenum with two 10-32x1/2" screws.
5. Start the remaining three 10-32x3" screws.
6. Tighten the four-plenum assembly screws evenly until the plenum fits snugly against headliner. Make sure that gasket does not shift out of place and electrical connectors remain attached.

COMPRESSOR INSTALLATION

See Compressor Mounting Instructions supplied in mount kit.

PLUMBING INSTALLATION

Plumbing schematic below is provided to speed installation of hoses.

TYPICAL REFRIGERANT FLOW PATTERN

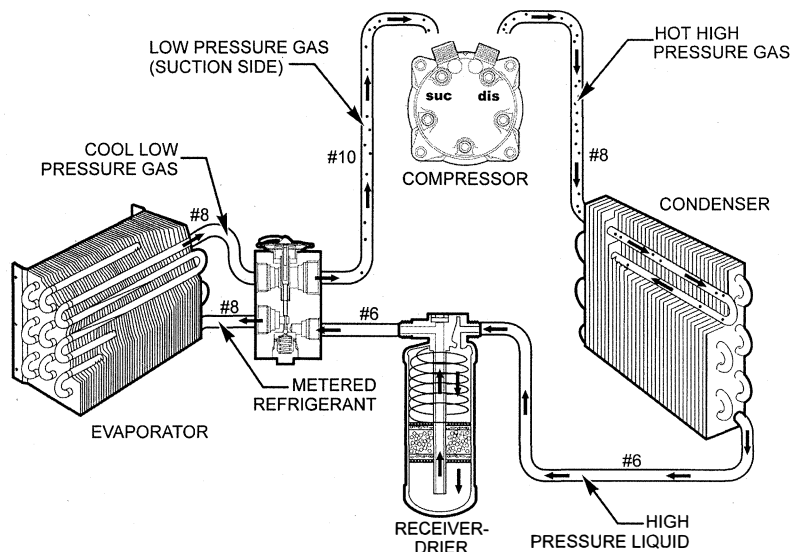

702 Series Wiring Diagram

Internal Wiring

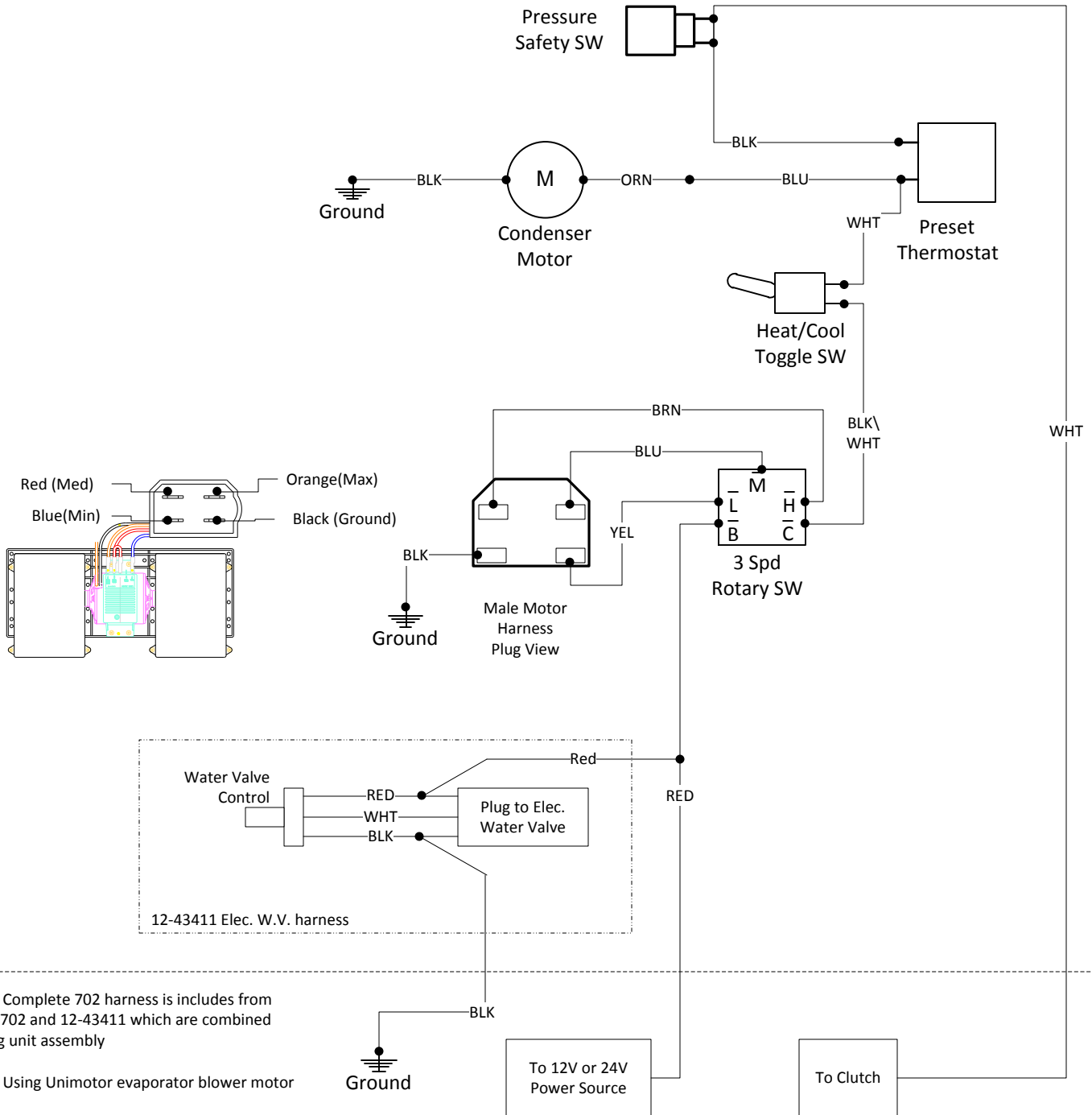

Note: Complete 702 harness is includes from 12-00702 and 12-43411 which are combined during unit assembly

Note: Using Unimotor evaporator blower motor

Caution: Do not change length of water valve wiring harness. Harness contains a resistor calibrated to a length of 14 feet.



Manufacturer of Heavy Equipment Heat/Cool Systems
5130 Edgefield Ln, TX 76065 USA
Phone 1-800-527-9477 Fax 1-800-299-5972
www.dtac.com

DTAC Charging A/C System Procedures

Leak Testing Procedure

1. With machine engine off, connect gauges to A/C system.
2. Charge with dry nitrogen. Up to 300 psi may be necessary to detect some leaks.
3. Spray all fittings and areas of concern with soapy water.
4. If bubbles are present or nitrogen pressures drop in fifteen minutes, repair leak and perform leak test again.
5. If nitrogen pressures maintain a constant level for fifteen minutes and no bubbles are present, proceed to the evacuating procedure.

Evacuating System Procedure

1. With machine engine off, connect gauges to A/C system.
2. Install center hose from gauge manifold to vacuum pump.
3. Turn the vacuum pump on.
4. Open the high and low side gauge manifold valves and the pump exhaust valves. System will reach 28-29.5 inches Hg. in not over 5 minutes. If system does not pump down, check connections and return to leak testing procedures if necessary.
5. Operate vacuum pump for a minimum of 1 hour for air and moisture removal.
6. Close all valves.
7. Shut off vacuum pump.
8. If pressures rise in 5 minutes, check connections and return to leak testing procedures if necessary.
9. If pressures hold level in a vacuum for 5 minutes proceed to charging procedures.

Charging Procedure

1. Gauges and A/C system must still be in a vacuum from the evacuating system procedure.
2. Place refrigerant bottle on scales.
3. Attach charging hose to refrigerant bottle.
4. Purge air from charging hose.
5. Open shut-off valve at refrigerant bottle.
6. Reset scales to zero if necessary.

7. With machine off, open high side manifold valve.
8. After gauge pressures become slow to increase, close high side manifold valve.
9. Start engine and throttle to working rpm.
10. Adjust A/C controls for maximum cooling and engage compressor clutch.
11. Open low side manifold valve.
12. Charge to weight recommended by manufacturer.
13. Check system for cooling.
14. If recommended weight is not available proceed to determine refrigerant weight procedure.

Determine Refrigerant Weight Procedure

1. Watch sight glass on drier. If bubbles clear on sight glass, system is full. However, some systems are full and still have bubbles in sight glass. Do not try to clear all bubbles if high side pressure is too high.
2. Try to keep low side pressure between 5-35 psi and the high side pressure lower than 295 psi. Keep in mind that pressure readings are greatly affected by ambient temperatures. For example, a high side reading of 295 psi on a 75 degree day would not be good while a high side reading of 300 psi on a 115 degree day would be acceptable, assuming the A/C system was cooling good.
3. Monitor vent temperature with doors closed to cab. If adding refrigerant lowers vent temperature, keep adding refrigerant as long as high side pressure is acceptable. When vent temperature levels out or starts rising, stop adding refrigerant. The goal is to have a 20 to 30 degree difference between the vent temperature and the air intake temperature at the internal filter. A 20 degree difference is acceptable and a 30 degree difference is excellent.
4. Return line at compressor should be cool and possibly sweating.
5. Cab temperature should be comfortable.
6. Check scales for proper weight and record for future use.



PREVENTATIVE MAINTENANCE

DTAC strives to manufacture A/C systems of superior quality. However, as with all mechanical equipment, normal maintenance must be performed for your A/C to function at peak capacity. A well-maintained A/C system will save on down time and premature component failures.

Weekly inspections or every 2 days in severe environments should include:

1. Inspect compressor clutch drive belts (tightness, wear).
2. Inspect compressor mounting brackets (bolts, alignment).
3. Inspect mounting hardware on evaporator unit and condensers.
4. Inspect air intake filter. (Clean or replace filter).
5. Inspect evaporator and condenser coils. (Clean using air pressure. **DO NOT USE WATER OR PRESSURE WASHERS**).
6. Inspect hose and wire harness for proper routing, leaks and wear.

Helpful Hints

Make sure the evaporator air intake area is not obstructed (i.e. toolboxes, clothing, lunch box, etc.).

Manual thermostats on our systems, when rotated clockwise to the stop position will not allow the A/C compressor clutch to cycle. The compressor will run continuously and the evaporator coil will not defrost. **REMEDY:** Turn the manual thermostat knob clockwise to the stop position, then turn the thermostat knob back counter clockwise $\frac{1}{4}$ turn.

DTAC thanks you for purchasing our units. It is our endeavor to provide you with a quality A/C unit with trouble free service.